

**Telescopic
Fusion Pro 90 cm
Anthracite**



EAN 5414425203550

Energy label

▪ Energy Efficiency class (EEIhood)	A
▪ Annual Energy Consumption (kWh/year) (AEChood)	39,3
▪ Fluid Dynamic Efficiency class (FDEhood)	A
▪ Lighting Efficiency class (LEhood)	A
▪ Grease Filtering Efficiency class (GFEhood)	C

Functions & features

▪ Control method	Touch control
▪ Number of speeds	3 + power
▪ Automatic Power revert (minutes)	6
▪ Motor	Integrated
▪ Sound absorber	Integrated
▪ Recirculation	Optional
▪ InTouch function	Standard
▪ Auto stop	▪
▪ Delayed switch off (minutes)	10
▪ Number of grease filters	3
▪ Grease filter	8740050

Dimensions

▪ Product dimensions (WxDxH) (mm)	900 x 310 x 340
▪ Dimensions cut-out opening (WxD) (mm)	x
▪ Min dimensions cabinet (WxDxH) (mm)	900 x 310 x 340
▪ Advised mounting height induction hobs (Hmin-Hmax) (mm)	500 - 750
▪ Advised mounting height gas hobs (Hmin-Hmax) (mm)	650 - 750
▪ Advised mounting height ceramic hobs (Hmin-Hmax) (mm)	500 - 750
▪ Diameter outlet (mm)	150
▪ Position exhaust	Top

Lighting

▪ Functional lighting type	Led strip
▪ Dimmable light	▪
▪ Total energy consumption functional light (W)	18
▪ Color functional light	4000

Airflow and noise level

▪ Free airflow (m ³ /h)	815
▪ Airflow (m ³ /h) measured according to EN 61591	
▪ Sound regulation according to EN 60704-2-13	
▪ Airflow speed 1 (m ³ /h) / Max Pressure speed 1 (Pa)	391 / 178
▪ Airflow speed 2 (m ³ /h) / Max Pressure speed 2 (Pa)	535 / 356
▪ Airflow speed 3 (m ³ /h) / Max Pressure speed 3 (Pa)	606 / 383

Airflow and noise level

▪ Airflow Powerspeed (m ³ /h) / Max Pressure Powerspeed (Pa)	674 / 383
▪ Sound pressure speed 1 (dB(A)) / Sound power speed 1 (dB(A))	36 / 48
▪ Sound pressure speed 2 (dB(A)) / Sound power speed 2 (dB(A))	44 / 56
▪ Sound pressure speed 3 (dB(A)) / Sound power speed 3 (dB(A))	47 / 59
▪ Sound pressure Powerspeed (dB(A)) / Sound Powerspeed (dB(A))	50 / 62

Technical specifications

▪ Maximum power	124
▪ Voltage (V)	220-230
▪ Frequency (Hz)	50
▪ Length power supply cord (m)	1,1
▪ Power consumption in stand-by-mode (Ps) (W)	0,25
▪ Net weight (kg)	14

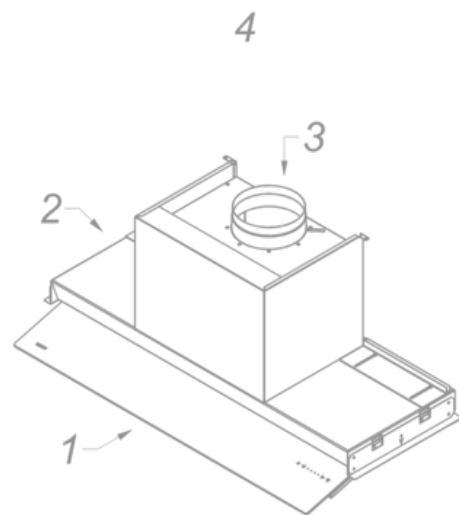
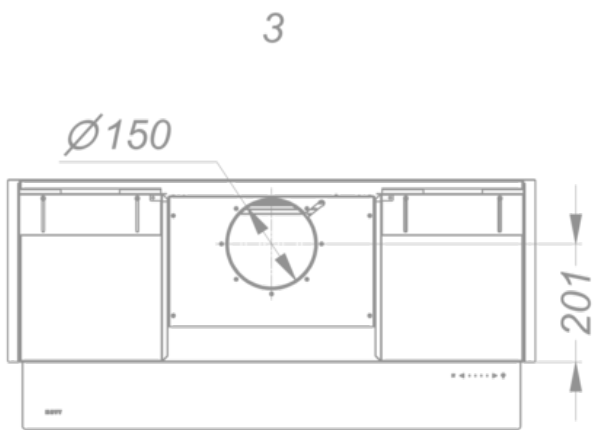
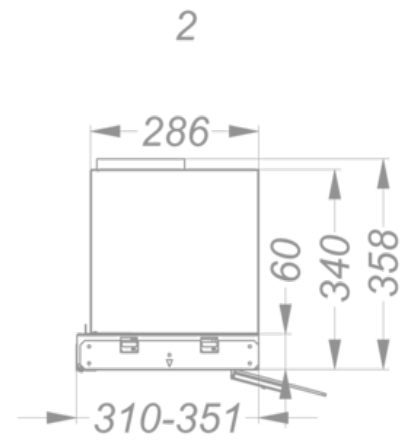
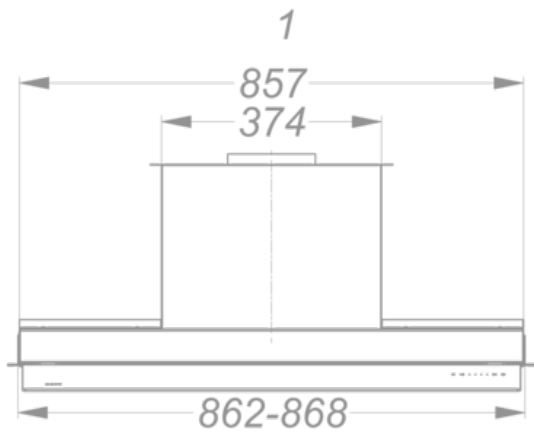

Accessories

Recirculation kit



8740400

Monoblock recirculation set Fusion Pro / Advanced

